

SUBMITTAL RECORD

JOB _____
LOCATION _____
SUBMITTED TO _____
SUBMITTAL PREPARED BY _____
APPROVED BY _____
DATE _____

DESCRIPTION

The Dyna-Stud is a heavy duty threaded stud with one end of an aircraft rated cable attached. Dyna-Stud is used to suspend duct work from a concrete structure. The stud is threaded into the expansion anchor without putting stress on the cable. This makes for a much safer and tighter connection. The raw end of the cable, in conjunction with the cable lock, is used to attach the object being supported.

**For ordering information,
 see reverse side.**

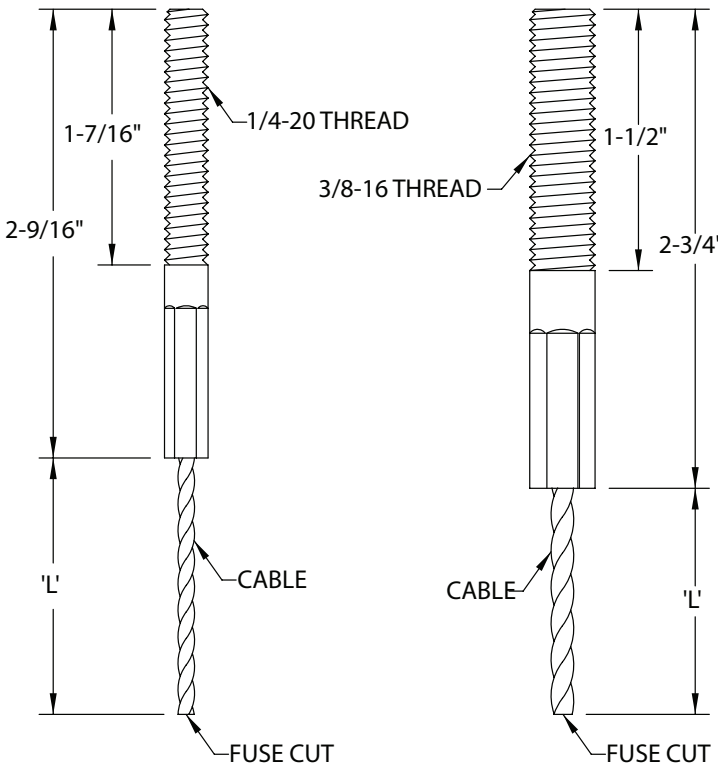

Submittal Form
Swaged Dyna-Stud®
Threaded Stud & Cable Assembly



SUGGESTED SPECIFICATION:

All ductwork and equipment shall be supported using wire rope cable terminated by Cable Locks. All Cable Locks shall have an Ultimate Breaking Strength (U.B.S.) of at least 5 times the published Working Load Limit (W.L.L.). Wire ropes shall be sized and spaced per manufacturers printed specifications. Wire Rope and Cable Locks shall be as supplied by Duro Dyne Corporation.

SPECIFICATION DATA

- 1) All wire rope supplied by Duro Dyne is statistically tested to minimum breaking strength.
- 2) Dyna-Tite Suspension System has been submitted and tested to be an acceptable alternative to the duct hanger systems prescribed in SMACNA HVAC-DCS 2nd edition By SMACNA Testing & Research Institute.
- 3) All Working Load Ratings of Dyna-Tite Cable Locks manufactured by Duro Dyne have been witnessed and verified by Independent Testing Labs.
- 4) Dyna-Tite Cable Locks may be used in temperatures up to 300 degrees F.
- 5) Dyna-Tite Cable Lock wedges are constructed of corrosion resistant sintered steel.
- 6) Dyna-Tite Cable Lock springs are constructed of tempered stainless steel.

WIRE ROPE SPECIFICATION
CARBON STEEL & GALVANIZED

Galvanized steel wire rope, supplied by Duro Dyne is manufactured to exacting standards and statistically tested to verify the breaking strength. Duro Dyne recommends only using wire rope supplied by Duro Dyne. The chart below outlines the specifications.

Wire Rope Size	Tolerance	Rope Construction
WC6-CL23	+0.018/-0.009	7x19
WC4-CL18	+0.014/-0.007 in	7x7
WC3-CL12	+0.012/-0.006 in	7x7

APPLICABLE SMACNA STANDARD
4.2.11 Hanging System Selection

The selection of a hanging system should not be taken lightly not only because it involves a significant portion of the erection labor, but also because an inadequate hanging system can be disastrous. In any multiple hanging system, the failure of one hanger transfers that load to adjacent hangers. If one of these fail, an even greater load is transferred to the next. The result is a cascading failure in which an entire run of duct might fail.

There are many hanger alternatives, especially in the upper attachments. Besides structural adequacy, the contractor's choice of hanging system must also take into account the particulars of the building structure, the skills of the workmen, the availability of tooling, and the recommendations of the fastener manufacturer. Because of these variables, it is suggested that the hanging system be the contractor's choice, subject to the approval of the mechanical engineer.



SUBMITTAL RECORD

JOB _____
LOCATION _____
SUBMITTED TO _____
SUBMITTAL PREPARED BY _____
APPROVED BY _____
DATE _____



Submittal Form Dyna-Stud® Threaded Stud & Cable Assembly

Ordering Information				
Item #	Code	Description	Use with Cable Lock	Safe Working Load*
30052	SDSA1405WC3	1/4in. Swaged Threaded Stud x 5ft WC3-CL12 Cable Assembly	CL12-WC3	25-150 lbs. (12-68 kg)
30053	SDSA1410WC3	1/4in. Swaged Threaded Stud x 10ft WC3-CL12 Cable Assembly	CL12-WC3	25-150 lbs. (12-68 kg)
30054	SDSA1415WC3	1/4in. Swaged Threaded Stud x 15ft WC3-CL12 Cable Assembly	CL12-WC3	25-150 lbs. (12-68 kg)
30055	SDSA1425WC3	1/4in. Swaged Threaded Stud x 25ft WC3-CL12 Cable Assembly	CL12-WC3	25-150 lbs. (12-68 kg)
30373	SDSA3805WC3	3/8in. Swaged Threaded Stud x 5ft WC3-CL12 Cable Assembly	CL12-WC3	25-150 lbs. (12-68 kg)
30374	SDSA3810WC3	3/8in. Swaged Threaded Stud x 10ft WC3-CL12 Cable Assembly	CL12-WC3	25-150 lbs. (12-68 kg)
30375	SDSA3815WC3	3/8in. Swaged Threaded Stud x 15ft WC3-CL12 Cable Assembly	CL12-WC3	25-150 lbs. (12-68 kg)
30376	SDSA3825WC3	3/8in. Swaged Threaded Stud x 25ft WC3-CL12 Cable Assembly	CL12-WC3	25-150 lbs. (12-68 kg)
30056	SDSA3805WC4	3/8in. Swaged Threaded Stud x 5ft WC4-CL18 Cable Assembly	CL18-WC4	25-225 lbs. (12-102 kg)
30057	SDSA3810WC4	3/8in. Swaged Threaded Stud x 10ft WC4-CL18 Cable Assembly	CL18-WC4	25-225 lbs. (12-102 kg)
30058	SDSA3815WC4	3/8in. Swaged Threaded Stud x 15ft WC4-CL18 Cable Assembly	CL18-WC4	25-225 lbs. (12-102 kg)
30059	SDSA3825WC4	3/8in. Swaged Threaded Stud x 25ft WC4-CL18 Cable Assembly	CL18-WC4	25-225 lbs. (12-102 kg)
30095	SDSA3805WC6	3/8in Swaged Threaded Stud x 5ft WC6-CL23 Dyna-Stud Cable Assembly	CL23-WC6	50-640 lbs.(25-291 kg)
30096	SDSA3810WC6	3/8in Swaged Threaded Stud x 10ft WC6-CL23 Dyna-Stud Cable Assembly	CL23-WC6	50-640 lbs.(25-291 kg)
30097	SDSA3815WC6	3/8in Swaged Threaded Stud x 15ft WC6-CL23 Dyna-Stud Cable Assembly	CL23-WC6	50-640 lbs.(25-291 kg)
30098	SDSA3825WC6	3/8in Swaged Threaded Stud x 25ft WC6-CL23 Dyna-Stud Cable Assembly	CL23-WC6	50-640 lbs.(25-291 kg)
1/4" & 3/8" drop ins sold separately.				
Cable Lock not included.				
*Safe Working Loads are based on a 5:1 Safety Factor				

WARNINGS

ALWAYS CONFIRM ENGAGEMENT OF CABLE LOCK ON WIRE BEFORE APPLYING THE LOAD: By pushing the adjustment pin in the opposite direction of the arrows on the cable lock and then pulling the cable also in the opposite direction of the arrows on the cable lock.

PULL ADJUSTMENT PIN BACK AND PASS WIRE ROPE THROUGH DYNA-TITE CABLE LOCK: Failure to pull adjustment pin first may cause damage to serrated teeth and reduce holding capacity.

TO ENSURE HANGING SYSTEM INTEGRITY AND SAFETY: Use only Duro Dyne wire rope.

WORKING LOAD LIMIT (WLL) MUST FALL WITHIN THE STATED WORKING LOAD RANGE OF THE CABLE LOCK: Each product is load rated and incorporates a minimum safety factor of 5:1. This WLL takes into account the specification criteria of the Dyna-Tite Cable Lock and the wire rope.

DO NOT USE ON COATED WIRE ROPE: It is important to maintain the metal to metal contact between the locking pawls in the Dyna-Tite and the wire rope.

SPRAY PAINTING: of the Dyna-Tite Cable Hanging System after installation is acceptable, at the installing contractor's discretion, if the installing contractor physically confirms engagement of each cable lock on the cable prior to and after painting, and in strict accordance with the Dyna-Tite Installation Instructions. Brush painting is not acceptable. Do not paint Cable or Cable Lock prior to installation. Do not reposition Cable Lock after painting.

DO NOT APPLY LUBRICANT: to any part of the assembly as this will alter the surface nature of the wire rope and attract dirt and debris.

DO NOT USE FOR LIFTING: (Under Hook slings) This product is designed for static load applications only.

KEEP THE PRODUCT CLEAN AND FREE FROM DIRT: Any dirt should be removed from the product prior to assembly.

INSPECT PERIODICALLY: Upon inspection, discard and replace if worn, distorted, or damaged.

REMOVE DAMAGED WIRE ENDS: Using a designated pair of wire rope cutters prior to inserting into the Dyna-Tite Cable Lock.

WHEN INSTALLING DURO DYNE DYNA-TITE CABLE ATTACHMENTS: to buildings or equipment careful consideration must be made to the attachment method and the material being attached to. It is the responsibility of the installer for the proper selection, installation and appropriateness of the attachment to the job specifications and any codes. Duro Dyne can give general guidance, but any questions regarding this should ultimately be directed to the project engineer of the job.

FOR DRY LOCATIONS ONLY

DO NOT USE IN CHLORINATED ATMOSPHERES SUCH AS POOLS AND NATATORIUM

GYMNASIUM INSTALLS MUST BE USING LOCKING CABLE LOCKS ONLY

Please see our Dyna-Tite testing and warnings webpage for the most detailed list of warnings:
<http://www.durodyne.com/DTTesting.php>

Duro Dyne Corporate Headquarters, Bay Shore, NY
 631-249-9000 • Fax: 631-249-8346

Duro Dyne Midwest • Duro Dyne West • Duro Dyne Canada
www.durodyne.com • E-mail: durodyne@durodyne.com



©2021 Duro Dyne Corporation
 Printed in USA 4/30/2021
 BO030414