

SPOT WELDER

SPOT WELDER MODELS TSP-1/TSP-2/TBW

MACHINERY
DIVISION

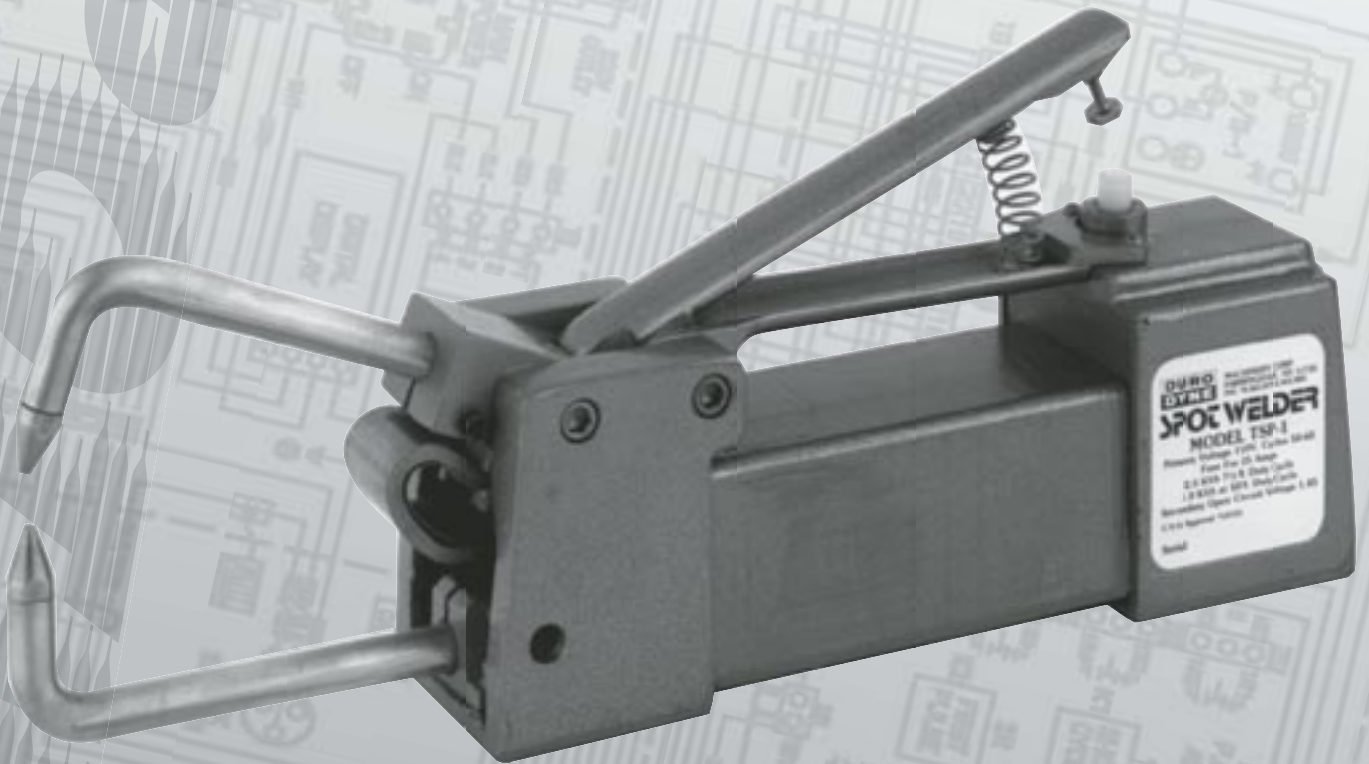

OWNER'S MANUAL

INTRODUCTION

Duro Dyne Spot Welders have over 50 years of proven reliability in shop environments. The latest models, TSP/TBW, incorporate the established durability with a built in solid state timer for weld accuracy and consistency. Optional accessories such as water cooled arms and the **ST-2 Spotwelder Stand** mean the TSP/TBW Spot Welders can be customized for your special needs in producing a top quality product.

To avoid unnecessary problems while using your TSP/TBW Spot Welder, please read this instruction manual fully and understand its contents completely.

IMPORTANT: Always follow manufacturer's recommendations for proper safety and handling procedures for all materials used in conjunction with this machine as outlined in Manufacturer's Safety Data Sheet (MSDS) for each product.

ELECTRICAL INSTALLATION

MODEL TSP-1 - 110V - Fuse for 30 amps
MODEL TSP-2 - 220V - Fuse for 15 amps
MODEL TBW - 220V - Fuse 30 amps

Connect the welder to a lightly loaded circuit supply line. For best results: Use a separate line as voltage drops can severely affect the efficiency of your welder.

WIRING CONNECTIONS

Welders are normally supplied with a 3 prong polarized plug to insure that the body of the welder is grounded. This is a safety precaution which should be taken on all electrical tools. In the event that you wish to use a plug other than the one supplied, the following diagram shows the welder connections:

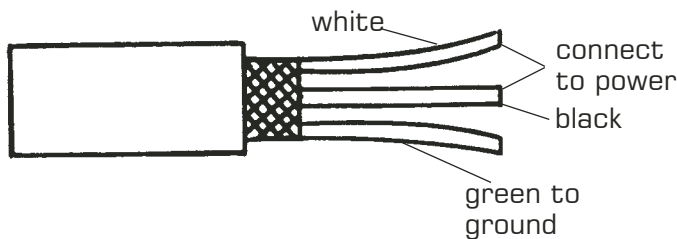

INSTALLATION OF ARMS

The arms of your welder should be inserted as follows:

1. Loosen slightly the 1/4-20 Allen Head Cap Screw on the side of the "nose piece." Insert top arm (shorter arm) all the way in, seat firmly and tighten screw.
2. Loosen slightly the 1/4-20 Allen Head Cap Screw on the side of "lower arm mounting" (hole in side of front body allows easy access). Insert lower arm deep enough so that tips meet exactly when arms are brought together. Tighten screw.
3. Recheck the alignment and readjust as necessary.

CONTROL SCREW ADJUSTMENT

Located on the underside of the welder handle, towards the back is a small, knurled screw. This screw determines the point at which the welder is activated after the welding tips are brought together against the metal. This switch control screw should be adjusted as follows:

1. Place metal between welding tips. Squeeze handle, applying moderate pressure to the welding tips.
Current should NOT yet be "ON."
2. Loosen jam nut. Adjust switch screw up or down, as the case may be, so that further pressure on the handle will activate switch and apply current. Tighten jam nut to lock adjustment.
3. This setting is changed only if the thickness of the metal being welded is changed greatly, or to compensate for the dressing of the tips.

NOTE: In some cases the range of switch adjustment may not be sufficient for proper setting. To adjust for new arms, remove the upper arm, place back end in a vise and bend slightly in the direction necessary to allow for proper adjustment.

ELECTRIC TIMERS

All TSP and TBW welders are supplied with solid state timers. The timer allows complete control of the welding cycle to assure fast and quality welding on even very light gauge steel. When properly adjusted the timer will eliminate "burn through."

The timer is adjustable from 1/10th to one (1) second. To adjust, simply turn the knob on the back of the welder until the desired time is set (counterclockwise to decrease; clockwise to increase).

TBW HI-LO SWITCH

When welding extremely light gauge metal the power of the TBW may be too hot to avoid "burn through." To "cool down" the TBW, a Hi-Lo switch was installed. When welding light gauge steel simply "flip" the Hi-Lo switch to Lo and adjust the timer as usual. Be sure to change the switch to Hi when going to heavy gauge or difficulty in welding will be experienced.

OPERATION OF THE WELDER

It is suggested that before using the Spot Welder on regular work, the operator should try welding pieces of scrap metal similar to the production material in order to determine the length of time it takes for proper fusion of the metals. The heavier the thickness of metals to be welded, the longer the timer must be on to perform a satisfactory weld.

WELDING GALVANIZED METALS

Since the galvanized coating is a poor conductor of electricity, it does not weld as readily as uncoated metal. The following simple procedure is suggested when welding galvanized iron:

1. As soon as current is applied, tilt the work so that the tips can "bite" into the coating. This will start the weld.
2. Keep handle depressed until weld cycle is complete. In cases of metal which is rusty or has a heavy scale, cleaning is recommended before welding.

In all cases, materials being welded should be clamped together so it will not be necessary for the arms to pull the material together.

CARE OF THE TIPS

The tips supplied are made of a top grade copper and will last a long time under normal conditions. Since the "power" of the welder is reflected in the diameter and cleanliness of the tips, it is recommended that the tips be kept at a diameter of not greater than 1/8". For best results, keep them at 3/32". Tips should be dressed by using a small mill file regularly. Keep them clean and to correct diameter.

GENERAL MAINTENANCE

Threaded Cone Tips (MT-3): Type MT-3 tip removal is simple, however, it is necessary to use the following procedure in order to break copper oxide scale which forms in the threads:

Place an open end wrench on the tip and hit the far end of the wrench with a sharp blow of a hammer. This breaks the bond, and the tip can easily be removed and replaced.

Taper Fit Tips (MT-1 & MT-2): Tap the part of the arm in which the tip is inserted, to loosen the tip. It should then drop out easily.

Other than the proper adjustment and care of the tips, there is little maintenance of the welder except to:

1. Make sure the line cord is not cut or damaged.
2. Make sure the plug wiring is secure and proper.
3. Remove the arms periodically to clean any scale with steel wool.

ACCESSORIES

Water Cooled Arms

Most standard arm styles are available with the water-cooling feature. These arms are especially useful where the heat generated in the arms is objectionable. Water-cooled arms allow for most efficient operation and longer tip life.

Welder Stand Model ST-2 Part# 9203

Allows all Duro Dyne Portable Spotwelders to be converted to stationary type units.

The welder is operated by means of a foot lever. The welder may be installed and removed with ease.

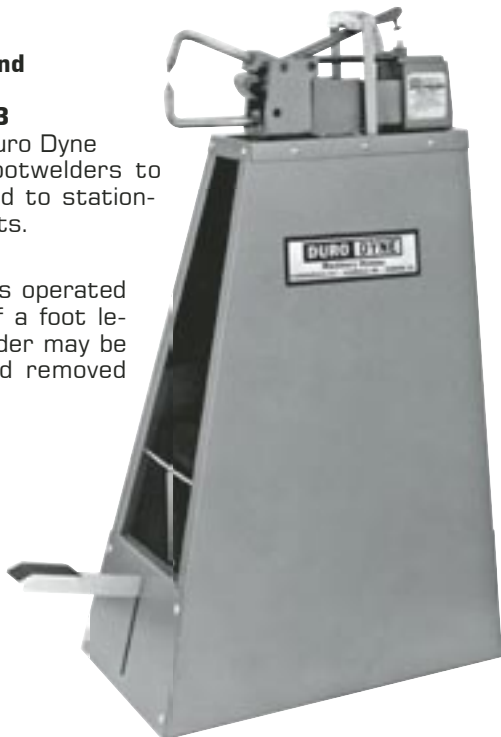

SPOT WELDER PARTS LIST

ITEM#	DESCRIPTION
9210	TSP/TBW Front Body
9211	TSP Rear Body
9212	TBW Rear Body
9213	TSP/TBW Rear Body Cover
9214	TSP Carriage
9215	TBW Carriage
9216	TSP/TBW Nose Piece
9217	TSP/TBW Lower Arm Mounting
9218	TSP Handle
9219	TBW Handle
9220	TSP/TBW Switch Mounting Bracket
9221	TSP/TBW Handle Spring
9222	TSP/TBW Actuator Spring
9223	TSP Nylon Actuator
9224	TSP/TBW Micro Switch
9225	TSP/TBW Switch Control Screw
9226	TSP Timer 110 Volt
9227	TSP/TBW Potentiometer
9228	TSP-1 Weld Transformer
9229	TBW Weld Transformer
9230	TSP Line Cord 110 Volt
9231	TSP2/TBW Line Cord 220 Volt
9232	TBW Hi/Lo Switch
9233	TSP/TBW Filter Screen
9234	TSP-1 Primary
9235	TBW Primary
9236	TSP Secondary
9237	TBW Secondary
9238	TSP/TBW Pivot Bolt
9239	TSP2/TBW Timer 220 Volt
9240	Line Cord Retainer
9241	TBW Nylon Activator
9242	TSP-2 Weld Transformer
9243	TSP-2 Primary

DURO DYNE WARRANTY

Duro Dyne Machinery is manufactured by skilled mechanics, utilizing the latest production techniques. Each unit has been rigorously tested prior to packaging and shipment in order to ensure troublefree operation.

Your Duro Dyne machine has a 90 day warranty against defects in material. Any component found to be defective will be repaired or replaced (at manufacturer's discretion) at no cost, if faulty component is returned freight prepaid to the nearest Duro Dyne Service Department. Warranty does not apply to expendable parts or repairs or service due to improper maintenance or operation procedures.

Duro Dyne products have been engineered to maximize operator safety. Unauthorized modification of this product will void the warranty.

All warranty claims must be accompanied by serial number, date of purchase and distributor purchased from.

For Service or Parts:

**Welder Service Department
Duro Dyne Corporation
Bay Shore, N.Y. 11706
Phone: 631-249-9000
Fax: 631-249-8346**

Give us the details of your problem. The answer is often simple, and in most cases eliminates unnecessary repairs.

PARTS LOCATION

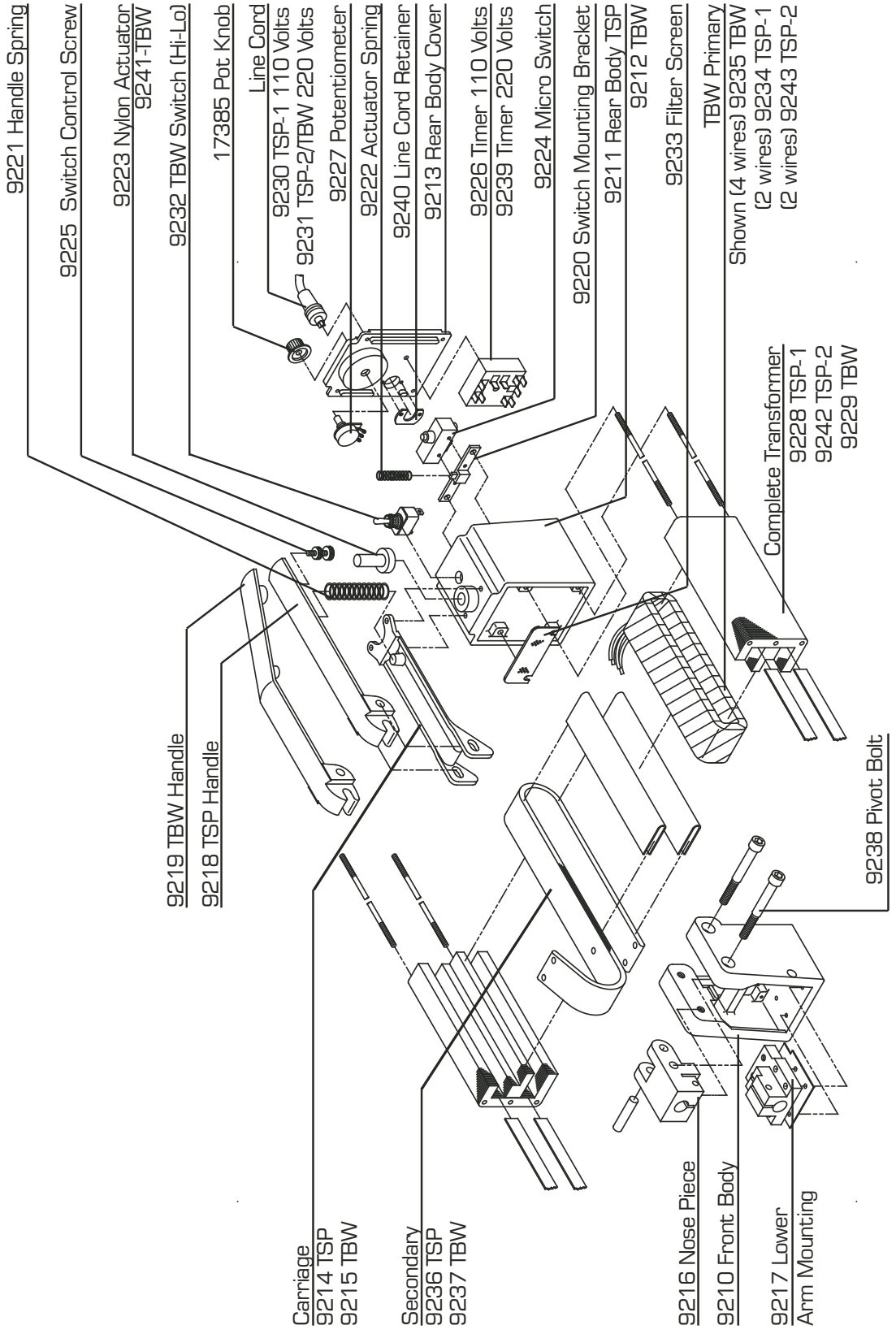

ACCESSORIES

TIPS

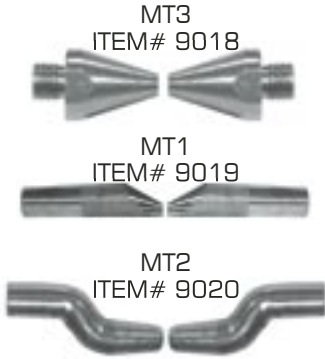

STANDARD ARMS

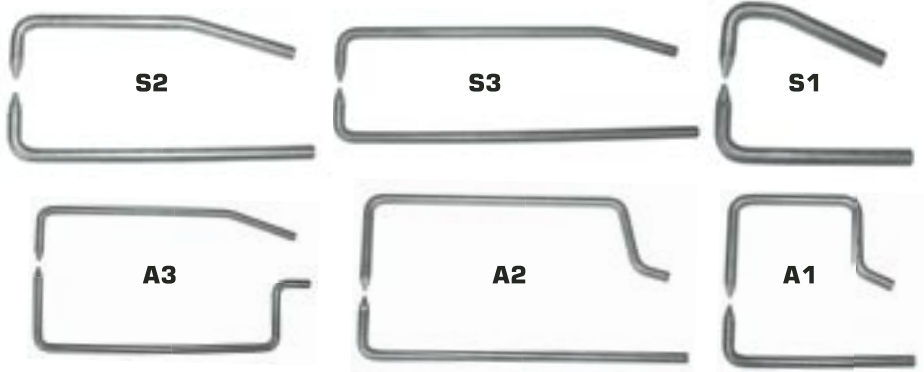

STANDARD			WATER COOLED			STANDARD			WATER COOLED		
Length	Descrip.	Item#	Length	Descrip.	Item#	Length	Descrip.	Item#	Length	Descrip.	Item#
6"	S-1	9012				6"	A-1	9015			
12"	S-2	9013	12"	S-2-W	9022	15"	A-2	9016	15"	A-2-W	9026
18"	S-3	9014	18"	S-3-W	9023	18"	A-3	9017	18"	A-3-W	9027

***NOTE: Dimensions reflect arms in closed position.**

WIRING DIAGRAMS

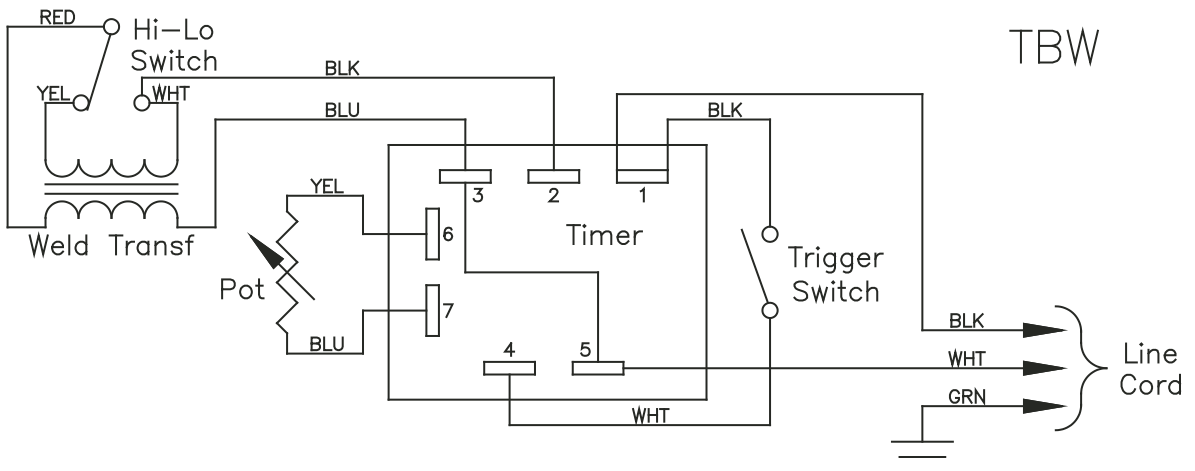
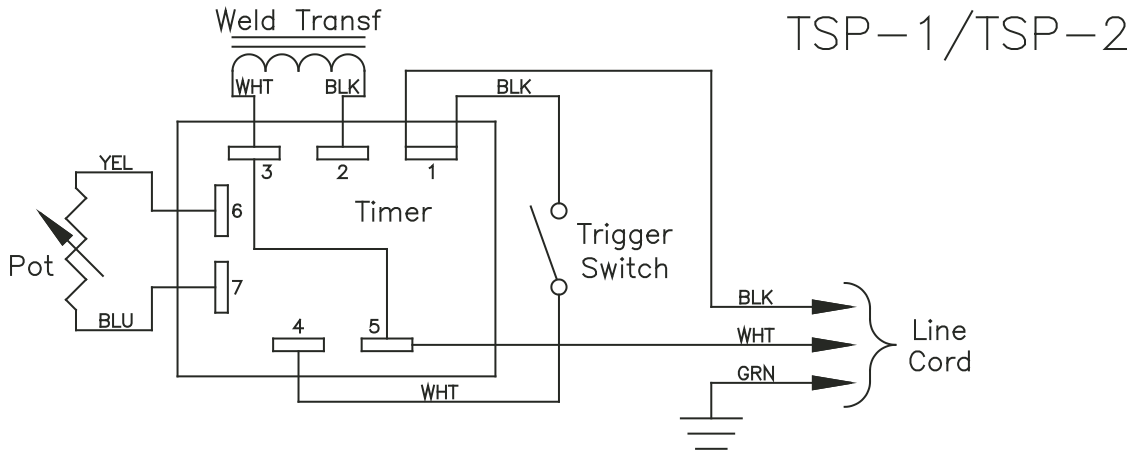

DURO DYNE®

The Greatest Name In Sheet Metal Necessities

Ask Your Duro Dyne Representative For The Complete Line Of
Duro Dyne Information and Pricing Catalogs

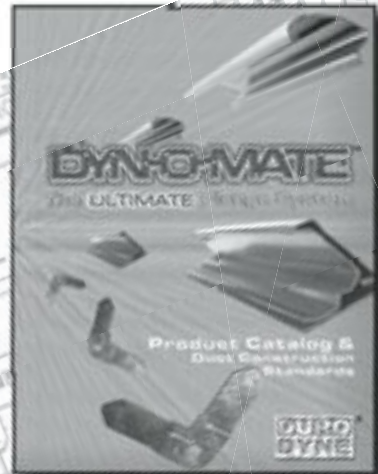
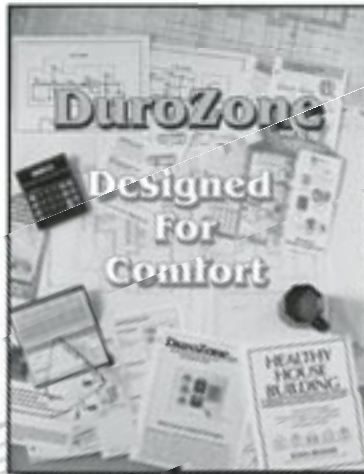
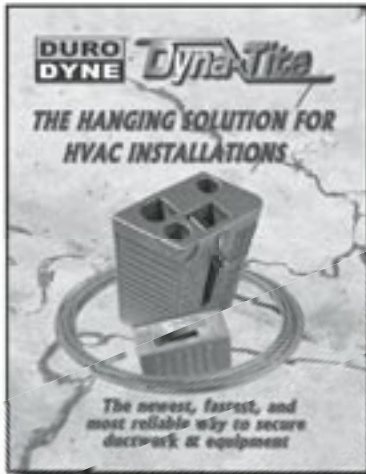

**DURO
DYNE®**

MACHINERY DIVISION

© 2006 Duro Dyne Corporation
Printed in USA 03/2006
B1009401

Duro Dyne East Division, Bay Shore, NY

Duro Dyne Midwest Division, Fairfield, OH

Duro Dyne West Division, Santa Fe Springs, CA

Duro Dyne Canada, Lachine, Quebec, Canada

631-249-9000 Fax: 631-249-8346

513-870-6000 Fax: 513-870-6005

562-926-1774 Fax: 562-926-5778

514-422-9760 Fax: 514-636-0328

www.durodyne.com E-mail: durodyne@durodyne.com