

DuroZone®

INSTALLATION INSTRUCTIONS

MULTIPLE POSITION MP SERIES DAMPERS

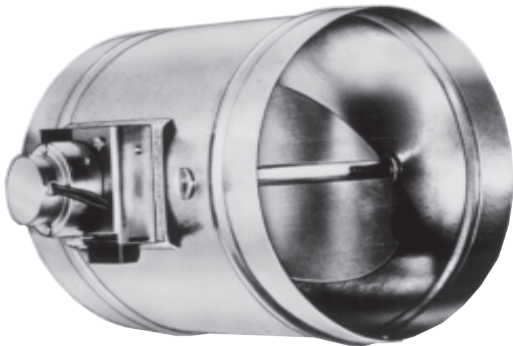

MOTOR TERMINALS

1. Trim 1/4" off the end of the Control Wiring.
2. Loosen the screw on the Damper Motor Terminal Strip.
3. Insert the trimmed Control Wire.
4. Tighten the screw down.

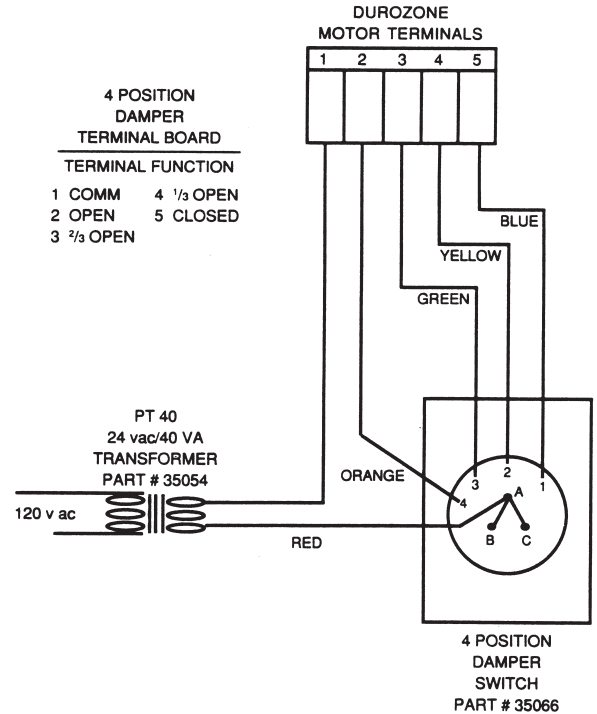
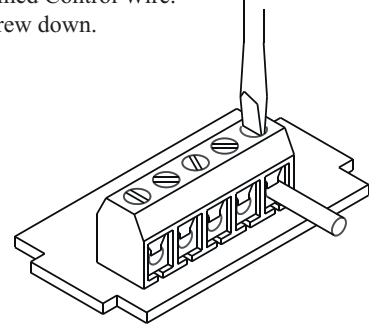

Duro Dyne East • Bay Shore, NY 11706 Phone: 631-249-9000 • Fax: 631-249-8346
 Duro Dyne Midwest • Fairfield, OH 45011 Phone: 513-870-6000 • Fax: 513-870-6005
 Duro Dyne West • Santa Fe Springs, CA 90670 Phone: 562-926-1774 • Fax: 562-926-5778
 Duro Dyne Canada • Lachine • Quebec • Canada Phone: 514-422-9760 • Fax: 514-636-0328

©2007 Duro Dyne Corporation
 Printed in USA 11/2007
 BP035417NEED NEW

ALL DuroZone DAMPERS FEATURE:

- 5 year limited warranty • Controlled bypass • Maintenance free operation • Quick install mounting clips (except Round Dampers) • 100% factory testing • Custom dampers and special controls are available on request.

DuroZone®

INSTALLATION INSTRUCTIONS

MULTI-BLADE ZONE CONTROL DAMPER

1. Cut a 3 3/8 inch wide slot into the side of the sheet metal duct.

2. Slide the Damper into the duct work.

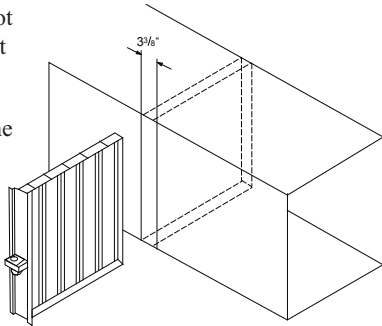

3. Insert the Quick Clip Fasteners through the slots in the damper outward to secure the Damper.

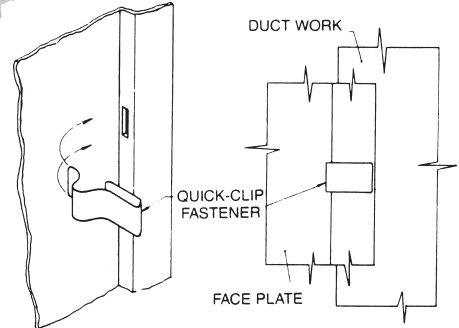

RD SERIES ROUND DAMPER

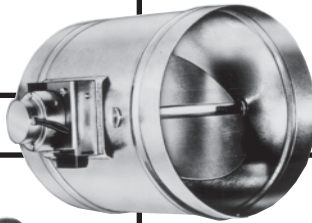

In flexible round duct

Slip the duct over the ends of the DuroZone section and secure it in place

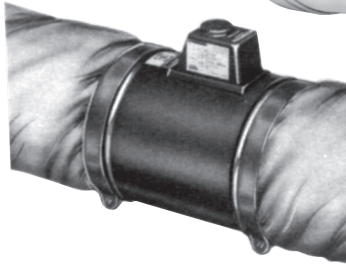

In rigid round duct

Slip the duct over the DuroZone section and screw it in place

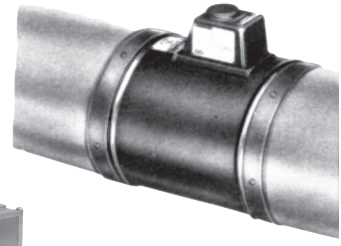

MS SERIES MULTI SIZE DAMPER

1. Determine the duct size and the damper size required.

2. Remove the four (4) screws from the frame end.

3. Adjust the damper blade to the desired size and position. Use Quick Clip Fasteners in indents on the blades to secure the blade halves.

4. Replace the same four (4) screws as in Step 2; tighten them completely.

5. With pliers, snap off the excess frame at the score mark bending downward first, then upward.

CAUTION

Do not bend too far initially, or the frame could be damaged.

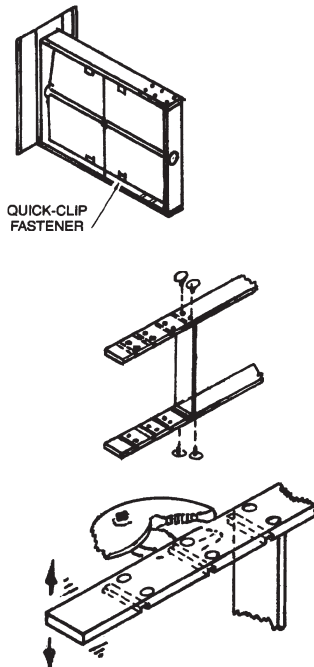

6. Fit the self-stick weatherstrip (included) to the damper frame before installing the damper. (Do not cover the blade pivot at the end opposite the motor.)

7. At the selected damper location, cut a 3 3/8 inch wide slot in side of the duct.

8. Slide the damper into position in the duct.

9. Slide the Quick Clip Fasteners outward to secure the damper.

